

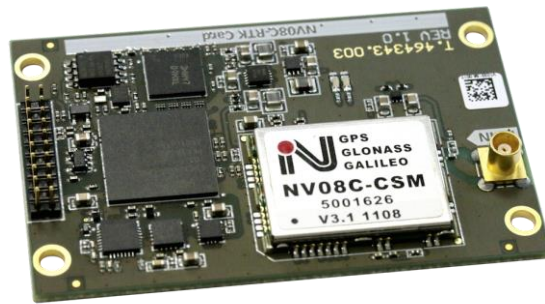

NVS Technologies AG

NV08C series



- Integrated RTK functionality
- L1 GPS, GLONASS and SBAS
- Data rate up to 20 Hz
- Base and Rover mode
- Centimeter-level positioning in RTK mode
- Individual GLONASS group delay calibration
- 3-stage filtration for high out-of-band interference immunity
- Enhanced RAIM for 3D and RTK modes
- Low power consumption
- Simple quick integration
- NMEA 0183, BINR, RTCM 3.1 communication protocols
- Industrial operating temperature range -40 to +85°C
- Integrated MEMS-sensors (INS)

NV08C-RTK

L1 GNSS Receiver for RTK applications

The **NV08C-RTK** is fully integrated multi-constellation satellite navigation receiver with embedded RTK functionality. The **NV08C-RTK's** key feature is its full compatibility with GPS, GLONASS and future global navigation satellite systems (GNSS) GALILEO and BeiDou. **NV08C-RTK** device is specifically designed for use in high accuracy applications, demanding low cost, low power consumption, small form factor and uncompromised performance.

Applications:

- Construction, Mining and Industrial
- Environmental & Structural Monitoring
- Machine control & automation
- Parallel driving systems
- Precision agriculture
- Unmanned aerial vehicle (UAV)
- Robotics and intelligent machines
- Land Surveying, 3D cartography, air photography



NVS Technologies AG
Letzastrasse 2
CH-9462 Montlingen
Switzerland
Tel: +41 71 760 0736
Fax: +41 71 760 0738
info@nvs-gnss.com

**NVS Navigation
Technologies Ltd.**
Kulneva, 3, bld.1
121170, Moscow
Russia
Tel: +7 495 660 06 30
Fax: +7 495 660 06 29
info@nvs-gnss.ru

WWW.NVS-GNSS.COM

Navigation Features

• Number of channels	32
• Satellite access mode	All-in-view
• GPS/GALILEO/SBAS	L1
• GLONASS	L1
• Accuracy (2D rms)*	
autonomous mode	2.5 m
SBAS	<1 m
RTK mode	1 cm + 1ppm
• Velocity measuring precision (rms)*	0.05 m/s
• Sensitivity	
tracking and re-acquisition	-160 dBm
acquisition	-143 dBm
RTK mode	-137 dBm
• Coordinate systems	WGS-84
• Time to First Fix	
Cold start	< 40 s
Warm start	< 35 s
RTK initialization time (after 3D fix)	< 10 s
Initialization reliability	99.9%

Environmental data

• Operating temperature	-40 to +85°C
• Maximum operating humidity	98% @ 40°C

Mechanical Features

• Size (LxWxH)	71 x 46 x 8.1 mm
• Weight (without package)	18 g

Main Features

- Rover and Reference Base Station modes support
- Easy to integrate
- Small size
- Low power consumption

Ordering options

- 10: Reference Base Station 1 Hz
- 15: Reference Base Station 1 Hz, Rover 1-5 Hz
- 20: Reference Base Station 1 Hz, Rover 1-20 Hz

* Typical values

Data Interfaces

• PVT output rate	1, 2, 5, 10 Hz
• Max Data output rate with INS	20 Hz
• Supported protocols	NMEA 0183 BINR (proprietary) RTCM 3.0, 3.1
• Host data interfaces	2x UART (3.3V CMOS-level) 1x USB 3.3V (D+, D-)
• Connectors	
Data:	PLD-20 male
Antenna:	MCX female
• Data exchange rate	Up to 460'800 bits/s

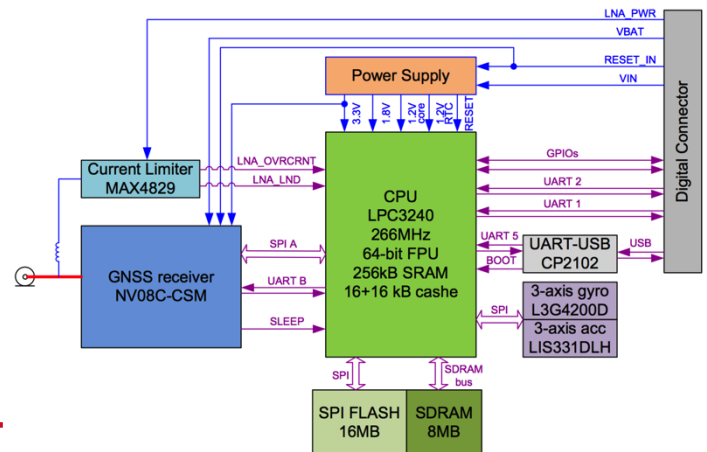

NV08C-RTK Receiver Block Diagram

Electrical specification

• Power supply voltage	3.3V - 5.0V
• Power consumption	
GNSS RTK-navigation	300 mW*

Accessories

- NV2410 high grade antenna
- NV08C-EVK-RTK evaluation kit